

Part No. AS4820-E-1200-090-D



Type EI48/20

Power 12.0VA

Weight 350g

shipping unit per box: 20 PCS

temperature class: ta 70°C/B

Vacuum filled casting

Split bobbin design winding

Dielectric strength 4500Vrms

| PART NO | Output ta 70°C/B | Prim.V | Connecting pins | Operating point sec. ± 10% | Connecting pins | No-load voltage V ± 10% |
|---------------------|------------------|--------|-----------------|-------------------------------|-----------------|----------------------------|
| AS4820-E-1200-090-D | 12.0W | 230 | 1--6 | 9V 666.6mA | 7--8 | 11.3V |
| | | | | 9V 666.6mA | 11--12 | 11.3V |

According to

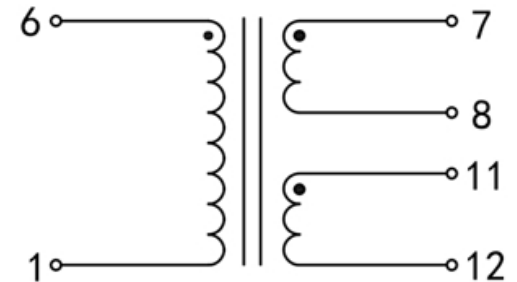
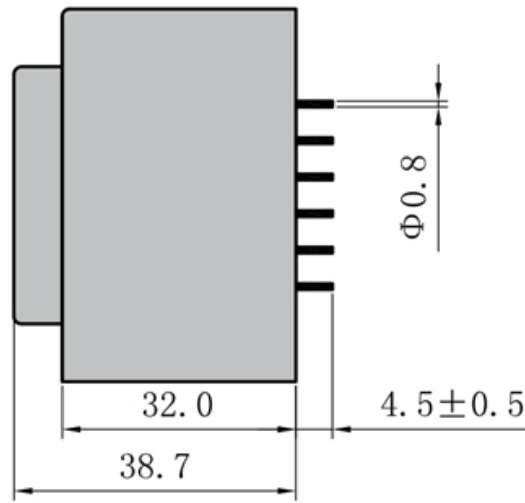
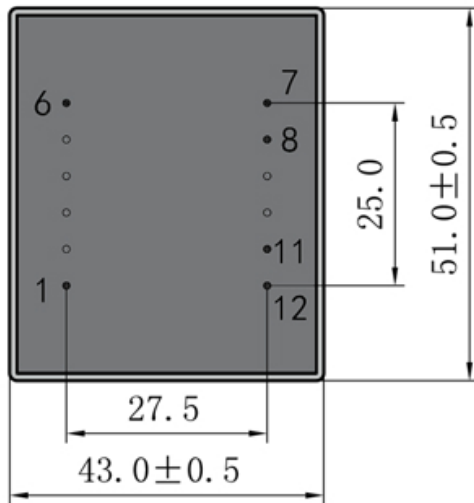

Dimensions with no indication of tolerances: ± 0.3mm
Custom-made transformer also will be welcome.



ADD: 699 Fangzhou Road Xiongzhou Town Luhe District 211500 Nanjing City Jiangsu China
TEL: +86 25 57120866 / 57120966 - 8001 FAX: +86 25 57118989
E-mail: asn@asn.cn / asn@asntransformer.com
http://www.asntransformer.com