

Part No. AS4816-U-1000-180-S



Type EI48/16.8

Power 10.0VA

Weight 295g

shipping unit per box: 20 PCS.

temperature class: ta 70°C/B

Vacuum filled casting

Split bobbin design winding

Dielectric strength 4500Vrms

| PART NO | Output ta 70°C/B | Prim.V | Connecting pins | Operating point sec. ± 10% | Connecting pins | No-load voltage ± 10% |
|---------------------|------------------|--------|-----------------|-------------------------------|-----------------|--------------------------|
| AS4816-U-1000-180-S | 10.0W | 115 | 1--6 | 18V 555.5mA | 8--11 | 11.4V |

According to

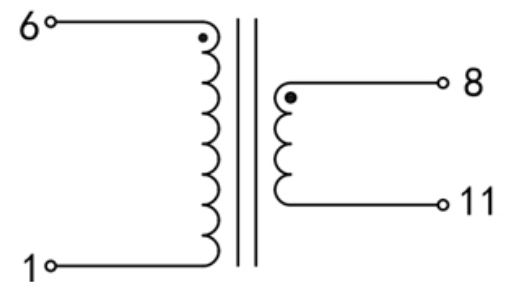
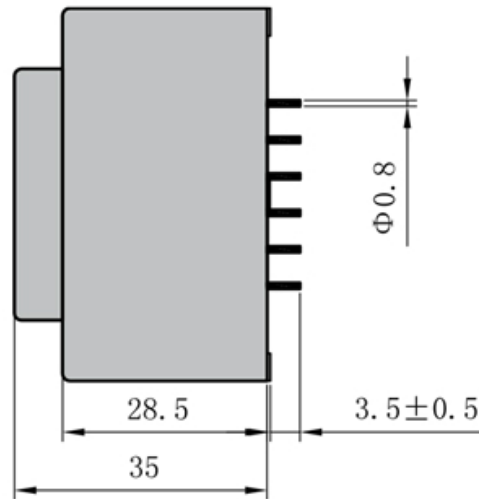
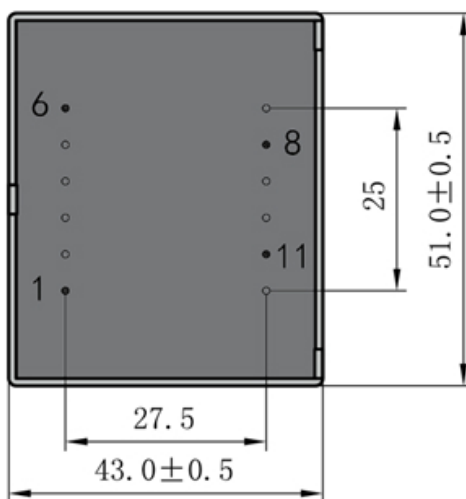

Dimensions with no indication of tolerances: ± 0.3mm
Custom-made transformer also will be welcome.



ADD: 699 Fangzhou Road Xiongzhou Town Luhe District 211500 Nanjing City Jiangsu China
 TEL: +86 25 57120866 / 57120966 - 8001 FAX: +86 25 57118989
 E-mail: asn@asn.cn / asn@asntransformer.com
 http://www.asntransformer.com