

Part No. AS4816-E-1000-180-S



Type EI48/16.8

Power 10.0VA

Weight 295g

shipping unit per box: 20 PCS.

temperature class: ta 70°C/B

**Vacuum filled casting**

Split bobbin design winding

**Dielectric strength 4500Vrms**

| PART NO             | Output ta 70°C/B | Prim.V | Connecting pins | Operating point<br>sec. ± 10% | Connecting pins | No-load voltage<br>± 10% |
|---------------------|------------------|--------|-----------------|-------------------------------|-----------------|--------------------------|
| AS4816-E-1000-180-S | 10.0W            | 230    | 1--6            | 18V 555.5mA                   | 8--11           | 22.8V                    |

According to

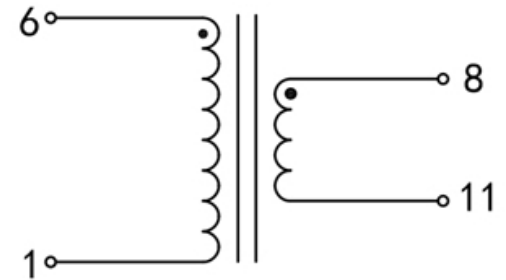
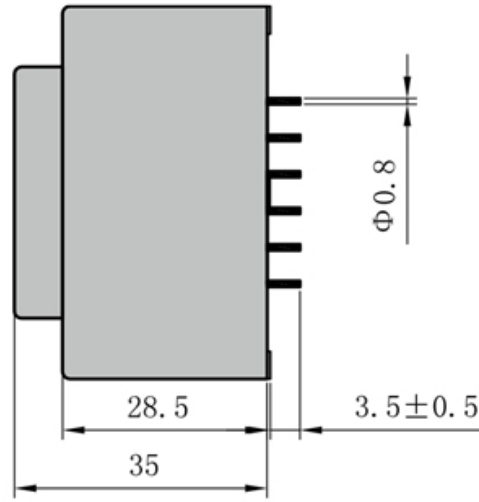
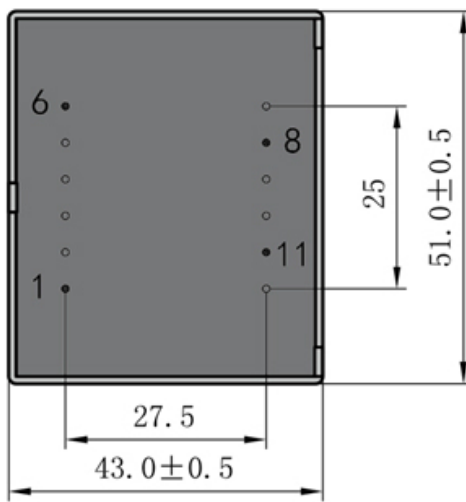

Dimensions with no indication of tolerances: ± 0.3mm  
Custom-made transformer also will be welcome.



ADD: 699 Fangzhou Road Xiongzhou Town Luhe District 211500 Nanjing City Jiangsu China

TEL: +86 25 57120866 / 57120966 - 8001

FAX: +86 25 57118989

E-mail: asn@asn.cn / asn@asntransformer.com

http://www.asntransformer.com